

ИНСТРУКЦИЯ ПО СБОРКЕ КАНБЕРРА тумба для ТВ 3

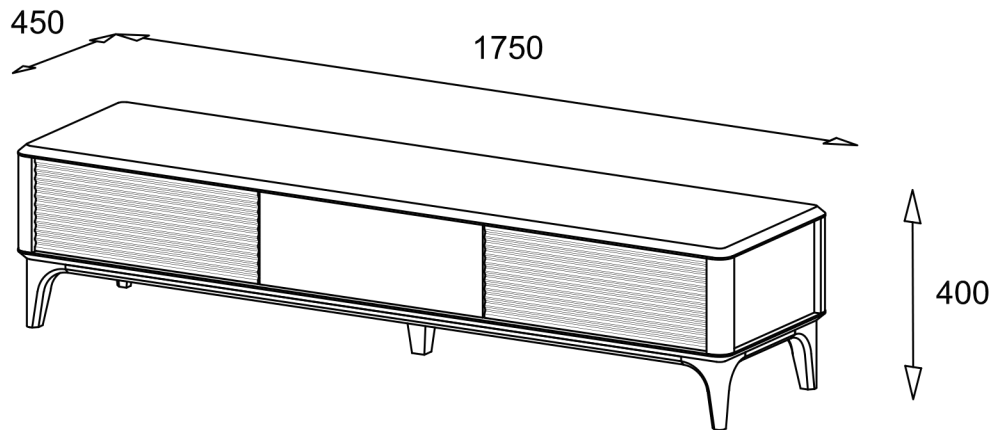

(ES) Instrucciones de montaje

(D) Montageanleitung

(FR) Notice de montage

(NL) Handleiding voor de montage

(CZ) Montážní návod

(HU) Szerelési útmutató

(TR) Montaj talimatları

(GB) Assembly instructions

(IT) Istruzioni di montaggio

(PL) Instrukcja montażu

(SK) Návod na montáž

(RO) Instrucțiuni de montaj

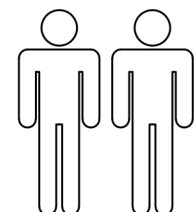
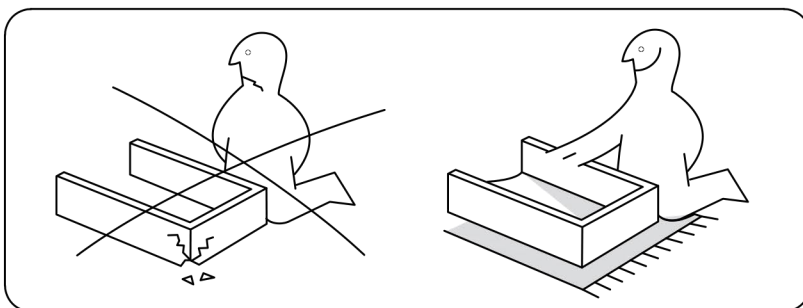
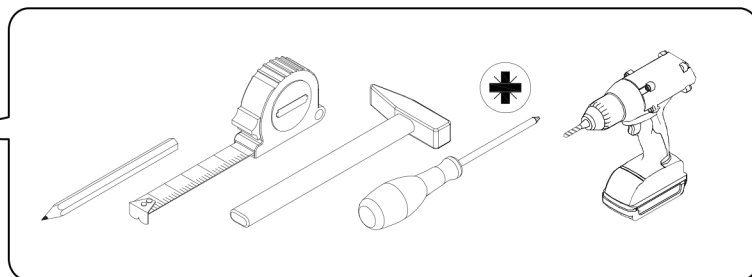
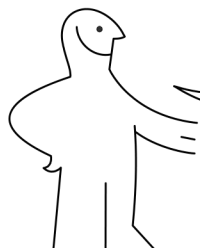

30 min

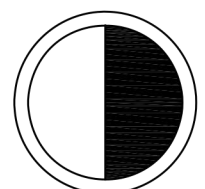

Name • Nom • Nome • Naam • Nazwa • Jaméno • Názov • Név • Denumire • Isim	
Nr. • No. • N° • Č • Sz	
Typ • Type • Tip • Tipus • Tipo	

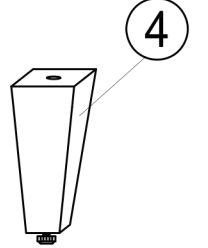
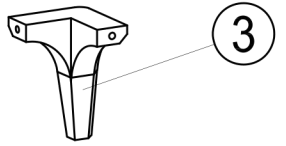
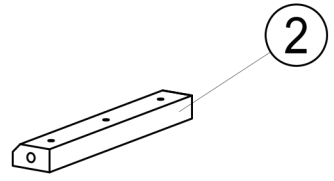
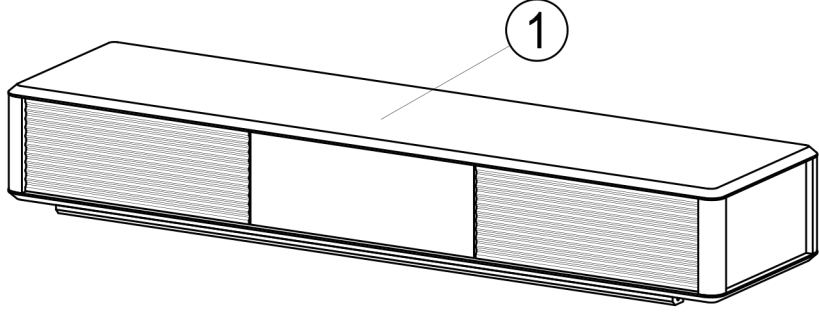
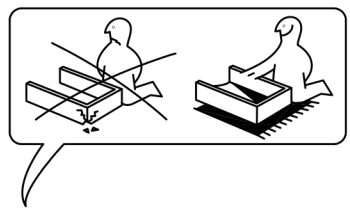
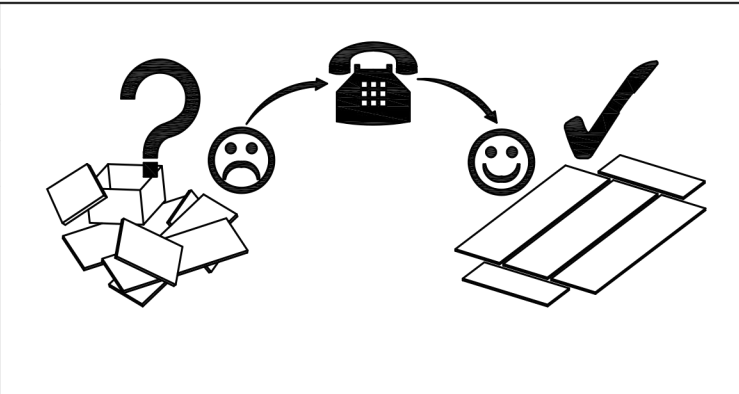

No	Size/MaB	Qty	✓
1	270x450x1750	1	
2	212x40x20	2	
3	150x100x100	4	
4	150x60x60	1	

A1 x1 Ø7x50	J4 x6 4x35	J2 x26 4x16	K1 x8 Ø8x35
O1 x1 k4 mm	P17 x4 	R1 x4 	

1

K1 x4

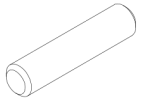

Ø8x35

2x

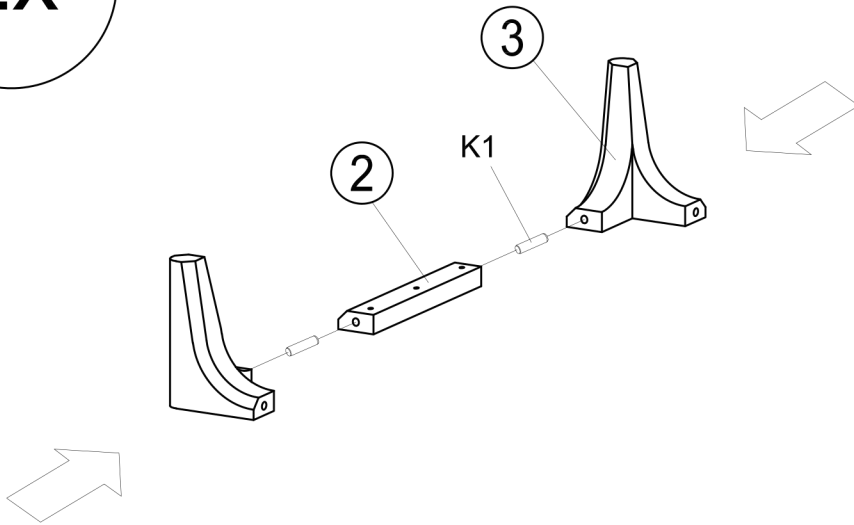

2

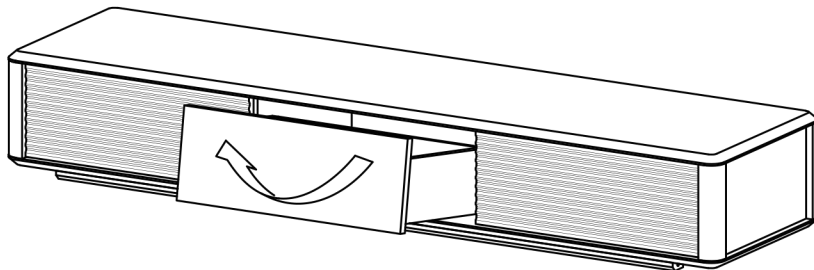

3

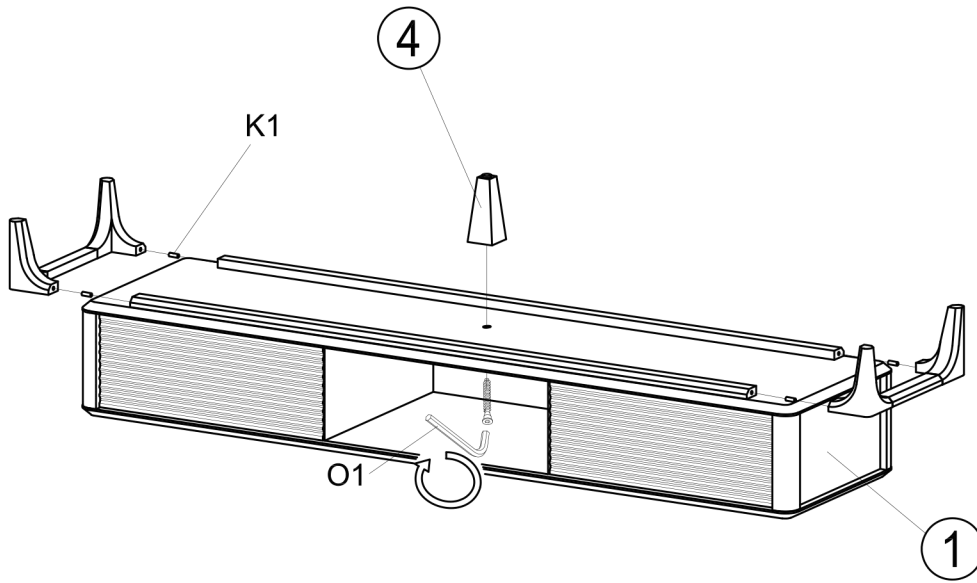

A1 x1

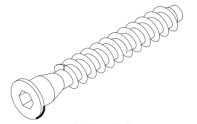

Ø7x50

K1 x4

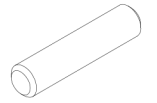

Ø8x35

O1 x1



k4 mm

4

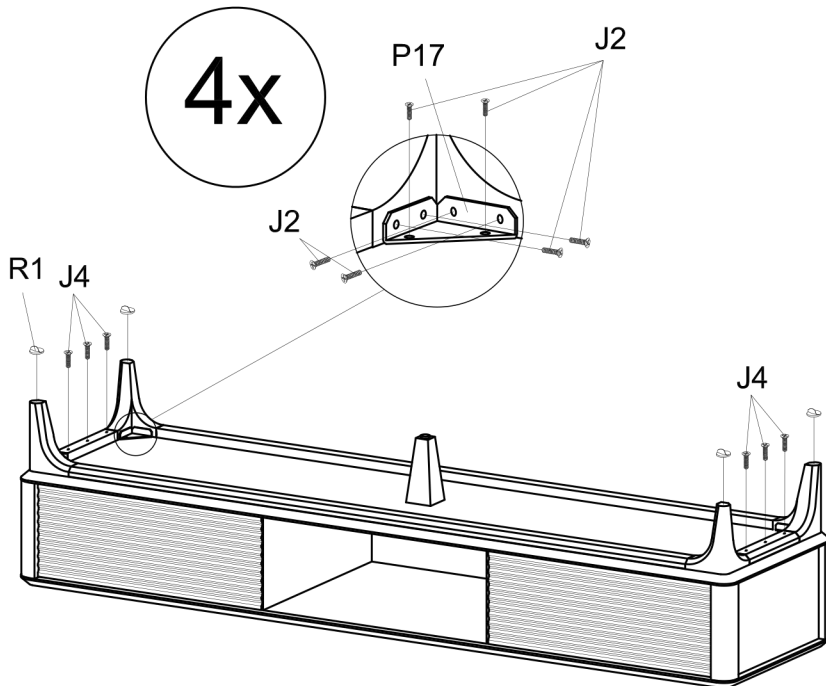

J2 x24

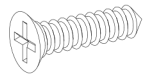

4x16

J4 x6

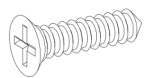

4x35

P17 x4

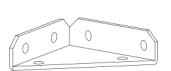

R1 x4



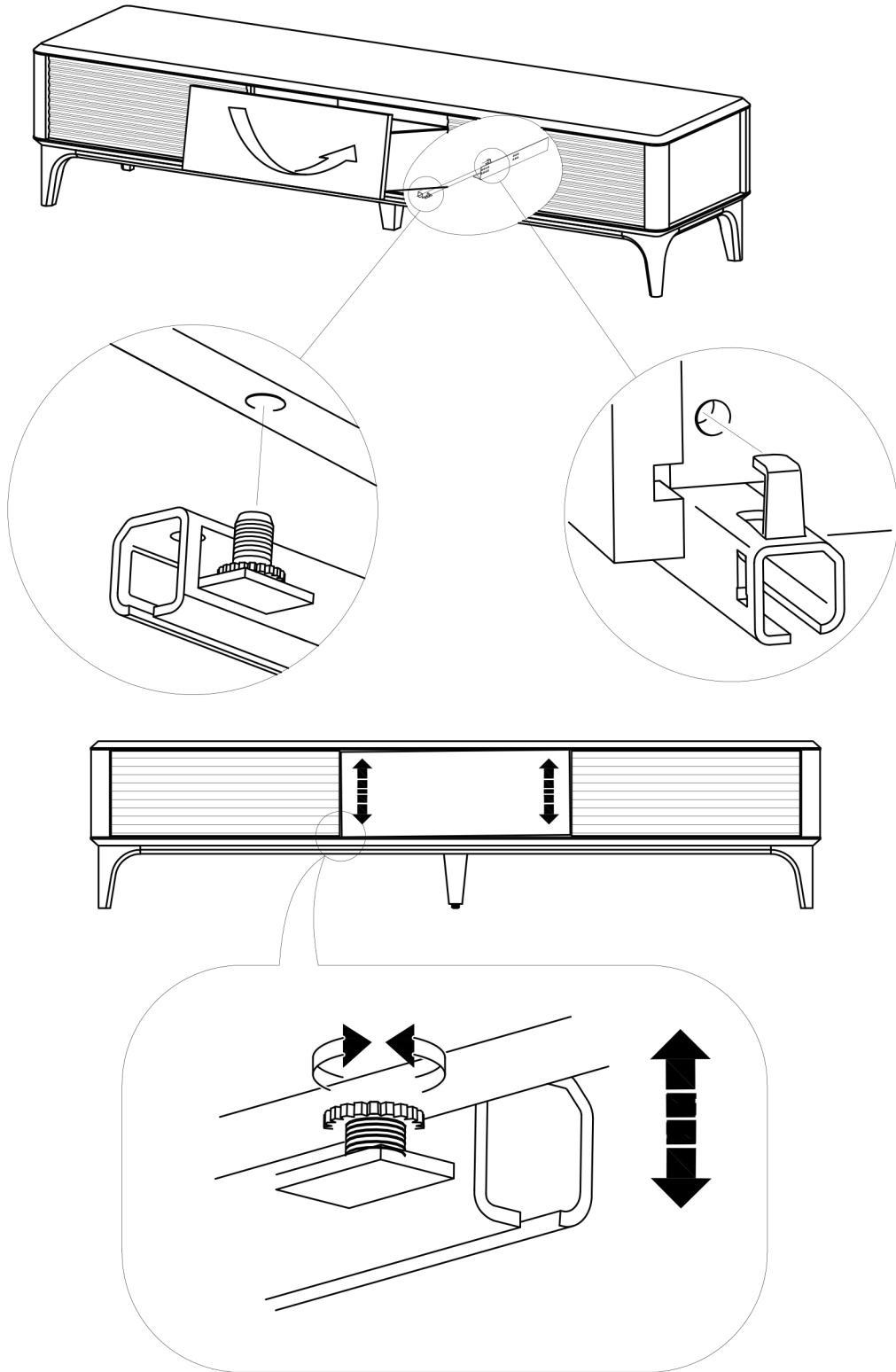

ES Por favor, limpie únicamente con un paño o un paño húmedo. No utilice limpiadores abrasivos.

D Bitte nur mit einem Staubtuch oder leicht feuchtem Lappen reinigen. Keine scheuernden Putzmittel verwenden.

GB Please only clean with a duster or a damp cloth. Do not use any abrasive cleaners.

FR Veuillez nettoyer uniquement avec un chiffon à poussière ou un chiffon légèrement humide. Ne pas utiliser de détergent abrasif.

IT Si raccomanda di pulire solo con un panno per la polvere o uno strofinaccio umido. Non utilizzare detergenti abrasivi.

NL Reinig alleen met een stofdoek of een lichtjes vochtige doek. Gebruik geen schurende poetsmiddelen.

PL Czyszczenie należy wykonać wyłącznie za pomocą ściereczki lub lekko nawilżonego ręcznika. Nie stosować środków czyszczących do szorowania.

CZ Čistěte prosím jen prachovkou nebo lehce navlhčeným hadrem. Nepoužívejte drhnoucí čisticí prostředky.

SK Na čistenie používajte len prachovku alebo zľahka navlhčenú utierku. Nepoužívajte žiadne drhúce čistiace prostriedky.

HU Kérjük, csak portörölő kendővel vagy enyhén nedves ronggyal tisztítsa. Ne használgjon dörzshatású tisztítószert.

RO Vă rugăm să utilizați la curățare exclusiv o cârpă de șters praful sau o cârpă ușor umezită. Nu utilizați substanțe de curățat abrazive.

TR Lütfen sadece bir toz bezyle veya hafif nemli yumuşak bir bezle siliniz. Aşındırıcı temizlik malzemeleri kullanmayınız.

